

**Образовательное частное учреждение
Дополнительного профессионального образования «Центр
компьютерного обучения «Специалист» Учебно-научного центра при
МГТУ им. Н.Э. Баумана»
(ОЧУ «Специалист»)**

123317 Москва, Пресненская набережная, д 8, стр. 1, этаж 48, помещение 484с, комната 5
ИНН 7701257303, ОГРН 1037739408189

Утверждаю:
Директор ОЧУ «Специалист»

/Т.С.Григорьева/
«15» марта 2018 года



**Дополнительная профессиональная программа
повышения квалификации
«Подготовка к сертифицированному экзамену на статус
Project Management Professional на основе PMI®
PMBOK® v.6»**

город Москва

Программа разработана в соответствии с приказом Министерства образования и науки Российской Федерации от 1 июля 2013 г. N 499 "Об утверждении Порядка организации и осуществления образовательной деятельности по дополнительным профессиональным программам".

Повышение квалификации слушателей, осуществляемое в соответствии с программой, проводится с использованием модульного принципа построения учебного плана с применением различных образовательных технологий, в том числе дистанционных образовательных технологий и электронного обучения в соответствии с законодательством об образовании.

Дополнительная профессиональная программа повышения квалификации, разработана образовательной организацией в соответствии с законодательством Российской Федерации, включает все модули, указанные в учебном плане.

Содержание оценочных и методических материалов определяется образовательной организацией самостоятельно с учетом положений законодательства об образовании Российской Федерации.

Структура дополнительной профессиональной программы соответствует требованиям Порядка организации и осуществления образовательной деятельности по дополнительным профессиональным программам, утвержденного приказом Минобрнауки России от 1 июля 2013 г. N 499.

Объем дополнительной профессиональной программы вне зависимости от применяемых образовательных технологий, должен быть не менее 16 академических часов. Сроки ее освоения определяются образовательной организацией самостоятельно.

Формы обучения слушателей (очная, очно-заочная, заочная) определяются образовательной организацией самостоятельно.

К освоению дополнительных профессиональных программ допускаются:

- лица, имеющие среднее профессиональное и (или) высшее образование;
- лица, получающие среднее профессиональное и (или) высшее образование.

Для определения структуры дополнительной профессиональной программы и трудоемкости ее освоения может применяться система зачетных единиц. Количество зачетных единиц по дополнительной профессиональной программе устанавливается организацией.

Образовательная деятельность слушателей предусматривает следующие виды учебных занятий и учебных работ: лекции, практические и семинарские занятия, лабораторные работы, круглые столы, мастер-классы, мастерские, деловые игры, ролевые игры, тренинги, семинары по обмену опытом, выездные занятия, консультации, выполнение аттестационной, дипломной, проектной работы и другие виды учебных занятий и учебных работ, определенные учебным планом.

1. Цель программы:

В результате прохождения обучения слушатель сможет пройти подготовку к сдаче сертификационного экзамена на статус РМР®

Совершенствуемые компетенции

№	Компетенция	Направление подготовки		
		ФГОС	ВО	ПО
		НАПРАВЛЕНИЮ ПОДГОТОВКИ 09.03.02 «ИНФОРМАЦИОННЫЕ СИСТЕМЫ И ТЕХНОЛОГИИ»		

		(УРОВЕНЬ БАКАЛАВРИАТА),
		Код компетенции
1	способностью разрабатывать, согласовывать и выпускать все виды проектной документации	ПК-10
2	способностью осуществлять организацию контроля качества входной информации	ПК-21
3	способностью выбирать и оценивать способ реализации информационных систем и устройств (программно-, аппаратно- или программно-аппаратно-) для решения поставленной задачи	ПК-37

Совершенствуемые компетенции в соответствии с трудовыми функциями профессионального стандарта «Руководитель проектов в области информационных технологий» (Зарегистрировано в Минюсте России 09.12.2014 N 35117)

№	Компетенция	Направление подготовки
		Трудовые функции (код)
1	Управление проектами в области ИТ любого масштаба в условиях высокой неопределенности, вызываемой запросами на изменения и рисками, и с учетом влияния организационного окружения проекта; разработка новых инструментов и методов управления проектами в области ИТ	С/01.8 – С/62.8

Планируемый результат обучения:

После окончания обучения Слушатель будет знать:

1. Общие требования и порядок прохождения сертификации
2. Рекомендации по подготовке и самопроверке перед экзаменом
3. Схемы процессов по РМВоК®
4. 10 областей знаний

После окончания обучения Слушатель будет уметь:

1. Грамотно подавать заявку на допуск к экзамену
2. Описывать проекты в своей заявке
3. Целенаправленно готовиться к сдаче сертификационных экзаменов PMI®: CAPM®, PMP®
4. Знать правила прохождения экзамена
5. Знать источники информации для подготовки к экзамену
6. Владеть основными типами вопросов

Данный курс соответствует требованиям профессионального стандарта **«Руководитель проектов в области информационных технологий»**

Учебный план:

Категория слушателей: курс предназначен для:

- Руководители проектов,
- Руководители разного уровня проектов, проектных офисов или аналогичных структур.
- Сотрудники и участники проектных команд
- Руководители среднего и высшего звена, которые используют или планируют использовать в своей работе проектные подходы
- Проектные менеджеры
- Все, кто планирует сдавать сертификационные экзамены CAPM® или PMP®

Требования к предварительной подготовке:

Успешное окончание курса «Управление проектами на основе стандарта ANSI PMI® PMBOK® Guide v.6 & Agile Practice Guide» или «Управление качеством в проектах и сервисах», Анализ и управление рисками в проектной и сервисной деятельности, Управление командой проекта. Роль и компетенции руководителя проекта, Календарное планирование и контроль проекта (на основе PMBOKv5 и с использованием MS Project)

Срок обучения: 16 академических часов, 8 самостоятельно

Форма обучения: очная, очно-заочная, заочная. По желанию слушателя форма обучения может быть изменена и/или дополнена.

Режим занятий: дневной, вечерний, группы выходного дня.

№ п/п	Наименование модулей по программе	Общая трудоемкость	Всего ауд. ч	В том числе		СРС	ПА*
				Лекций	Практических занятий		
1	Модуль 1. Общие требования: порядок регистрации и прохождения	3	2	2	0	1	Уст. пров.
2	Модуль 2. Типы вопросов	2	1	0	1	1	Уст. пров.
3	Модуль 3. Рекомендации по подготовке	2	1	1	0	1	Уст. пров.
4	Модуль 4. Пробный экзамен	4	3	1	2	1	Уст. пров.
5	Модуль 5. Схемы процессов PMBoK®.	7	5	2	3	2	Уст. пров.
6	Модуль 6. Итоговый пробный экзамен. Подведение итогов	6	4	1	3	2	Уст. пров.
	ПА*-форма промежуточной аттестации (уст.пров-устная проверка)						Уст. пров.
	Итого:	24	16	7	9	8	
	Итоговая аттестация	тестирование					

Для всех видов аудиторных занятий академический час устанавливается продолжительностью 45 минут. Форма промежуточной аттестации – см. в ЛНА «Положение о проведении промежуточной аттестации слушателей и осуществлении текущего контроля их успеваемости» п.3.3

2. Календарный учебный график

Календарный учебный график формируется при осуществлении обучения в течение всего календарного года. По мере набора групп слушателей по программе составляется календарный график, учитывающий объемы лекций, практики, самоподготовки, выезды на объекты.

Неделя обучения	1	2	3	4	5	6	7	Итого часов
	пн	вт	ср	чт	пт	сб	вс	
1 неделя	8	4	4ИА	-	-	-	-	16
СРС	4	4						8
Итого:								16/8
Примечание: ИА – Итоговая аттестация (тестирование)								

3. Рабочие программы учебных предметов

Модуль 1. Общие требования и порядок прохождения

- Преимущества сертификаций
- Обзор сертификационных программ
- Требования PMI® для прохождения сертификации
- Порядок регистрации и подтверждения опыта и PDU

Модуль 2. Типы вопросов

- Разбор типов вопросов
- Вопросы – кейсы
- Вопросы на знание формул
- Вопросы по профессиональной этике

Модуль 3. Рекомендации по подготовке и самопроверке перед экзаменом

- Порядок подготовки
- Как проверить себя
- Подготовка непосредственно перед экзаменом

Модуль 4. Пробный экзамен.

- Прохождение пробного экзамена (первая попытка)

Модуль 5. Схемы процессов по PMBoK®

- На что обращать внимание
- 10 областей знаний
- Разбор входов, методов и инструментов, и выходов процессов
- Примеры формулировок вопросов

Модуль 6. Пробный экзамен. Имитация экзамена

- Прохождение пробного экзамена

- Сравнение результатов попыток и ответы на вопросы

Организационно-педагогические условия

Соблюдение требований к кадровым условиям реализации дополнительной профессиональной программы:

а) преподавательский состав образовательной организации, обеспечивающий образовательный процесс, обладает высшим образованием и стажем преподавания по изучаемой тематике не менее 1 года и (или) практической работы в областях знаний, предусмотренных модулями программы, не менее 3 (трех) лет;

б) образовательной организацией наряду с традиционными лекционно-семинарскими занятиями применяются современные эффективные методики преподавания с применением интерактивных форм обучения, аудиовизуальных средств, информационно-телекоммуникационных ресурсов и наглядных учебных пособий.

Соблюдение требований к материально-техническому и учебно-методическому обеспечению дополнительной профессиональной программы:

а) образовательная организация располагает необходимой материально-технической базой, включая современные аудитории, библиотеку, аудиовизуальные средства обучения, мультимедийную аппаратуру, оргтехнику, копировальные аппараты. Материальная база соответствует санитарным и техническим нормам и правилам и обеспечивает проведение всех видов практической и дисциплинарной подготовки слушателей, предусмотренных учебным планом реализуемой дополнительной профессиональной программы.

б) в случае применения электронного обучения, дистанционных образовательных технологий каждый обучающийся в течение всего периода обучения обеспечивается индивидуальным неограниченным доступом к электронной информационно-образовательной среде, содержащей все электронные образовательные ресурсы, перечисленные в модулях дополнительной профессиональной программы.

4. Формы аттестации и оценочные материалы

Образовательная организация несет ответственность за качество подготовки слушателей и реализацию дополнительной профессиональной программы в полном объеме в соответствии с учебным планом.

Оценка качества освоения дополнительной профессиональной программы слушателей включает текущий контроль успеваемости и итоговую аттестацию.

Результаты итоговой аттестации слушателей ДПП в соответствии с формой итоговой аттестации, установленной учебным планом, выставляются по двух бальной шкале («зачтено\незачтено»).

Слушателям, успешно освоившим дополнительную профессиональную программу и прошедшим итоговую аттестацию, выдается удостоверение о повышении квалификации.

Слушателям, не прошедшим итоговой аттестации или получившим на итоговой аттестации неудовлетворительные результаты, а также лицам, освоившим часть дополнительной профессиональной программы и (или) отчисленным из образовательной организации, выдается справка об обучении или о периоде обучения по образцу, самостоятельно устанавливаемому образовательной организацией.

Итоговая аттестация проводится по форме тестирования в соответствии с учебным планом. Результаты итоговой аттестации заносятся в соответствующие документы.

5. Вопросы промежуточной аттестации:

1. COSM 591: Which statment is NOT true concerning EVM (Earned Value Management)?

2. COSP 586: Which of the following statements is generally true concerning analogous estimates?
3. 018: Which of the following elements is an output of the process “Plan procurements”?
4. COME 712: Which of the following models of conflict resolution allows a cooling off period, but seldom resolves the issue in the long term?
5. II 56: Which of the following is true regarding constraints and assumptions?
6. 644: Your preferred resource is not available at the time needed. What is the best thing to do?
7. II 74: Which of the following is best for handling cross-functional project needs for a large, complex project?
8. COSM 591: Which statment is NOT true concerning EVM (Earned Value Management)?

6. Итоговое тестирование «Пробный тест на сертификационный экзамен PMP»

Teleboard PMP Preparation Test

Вопрос 1/199

TP 350: ___ and ___ could be ways to accelerate the project schedule.

Выберите один ответ:

- Fast tracking, crashing
- Rushing, crashing
- Retracking, crashing
- Fast tracking, rowing

Вопрос 2/199

SP 240: Components of the scope baseline include all the following EXCEPT:

Выберите один ответ:

- WBS dictionary
- WBS
- Project scope statement
- Requirements traceability matrix

Вопрос 3/199

RP 895: A diagram that depicts key interactions among decisions and associated chance events is called a:

Выберите один ответ:

- WBS
- Gantt chart
- Decision maker

- Decision tree

Вопрос 4/199

COSP 586: Which of the following statements is generally true concerning analogous estimates?

Выберите один ответ:

- It is costly and more time consuming than other techniques
- It uses a statistical relationship between historical data and other variables
- It is frequently used to estimate a parameter when there is a limited amount of detailed information about the project
- The cost of individual work packages is estimated with the greatest level of specified detail

Вопрос 5/199

TP 328: A modification of a logical relationship that allows an acceleration of the successor task is represented by:

Выберите один ответ:

- Lag
- Lead or Lag
- Lead
- Negative Lead

Вопрос 6/199

HE 630: In building team confidence , a project manager should _____ with team members and avoid _____

Выберите один ответ:

- set limited times and opportunities for discussions; social contracts
- encourage frank discussions; making promises
- encourage open conversations; politics
- practice what he preaches; social contracts

Вопрос 7/199

029: The best two charts to show trends in a process are _____ and _____ .

Выберите один ответ:

- Control, Run
- CPM, Run
- Pert diagram, Gantt

- Pareto , Gantt

Вопрос 8/199

QM 030: You are a project manager for a major systems integration project. The head of the quality department comes to see you: he wants to start a quality audit of your main project. The team, already under pressure, takes strong objection to the audit. You should explain to the team that the purpose of a quality audit is meant _____

Выберите один ответ:

- To check the accuracy of the costs submitted by the team
- To identify lessons learned that can improve performance on the project
- Part of an ISO 9000 investigation
- To check if the customer is following its quality process

Вопрос 9/199

PP 055: You are designing a matrix giving each supplier some points according to their potential abilities to deliver the goods and to whether they are represented locally or not. Your activity belongs to which process?

Выберите один ответ:

- Conduct the Make or Buy decision
- Conduct procurements
- Administer procurements
- Plan procurements

Вопрос 10/199

RM 866: During the course of your project an unexpected risk materializes. You never thought that such a thing could happen in your project; however, your project has provisions for contingency and management reserves. How should these costs be accounted for?

Выберите один ответ:

- Buffer reserve
- Management reserve
- Safety reserve
- Contingency reserve

Вопрос 11/199

018: Which of the following elements is an output of the process "Plan procurements"?

Выберите один ответ:

- Contract Types

- Make-or-buy analysis
- Make-or-buy decisions
- Requirements documentation

Вопрос 12/199

COMM 718: All the following are useful interpersonal skills or behaviour for negotiation EXCEPT:

Выберите один ответ:

- When you make a concession, act as if you are yielding something of value
- Differentiate between wants and needs, both theirs and yours
- Ask high and offer low, but be realistic
- Hide the truth and do not show your cards

Вопрос 13/199

COME 712: Which of the following models of conflict resolution allows a cooling off period, but seldom resolves the issue in the long term?

Выберите один ответ:

- Withdrawal
- Forcing
- Problem solving
- Smoothing

Вопрос 14/199

II 56: Which of the following is true regarding constraints and assumptions?

Выберите один ответ:

- Constraints are considered true for planning purposes, and assumptions limit the options of the project team
- Constraints consider vendor availability and resource availability to be true for planning purposes. Assumptions limit the project team to work within predefined budgets or time lines
- Constraints restrict the actions of the project team, and assumptions are considered true for planning purposes
- Constraints and assumptions are inputs to the Initiation process. They should be documented, as they will be used throughout the project planning process

Вопрос 15/199

TP 426: Using the following network diagram which activities are on the critical path?

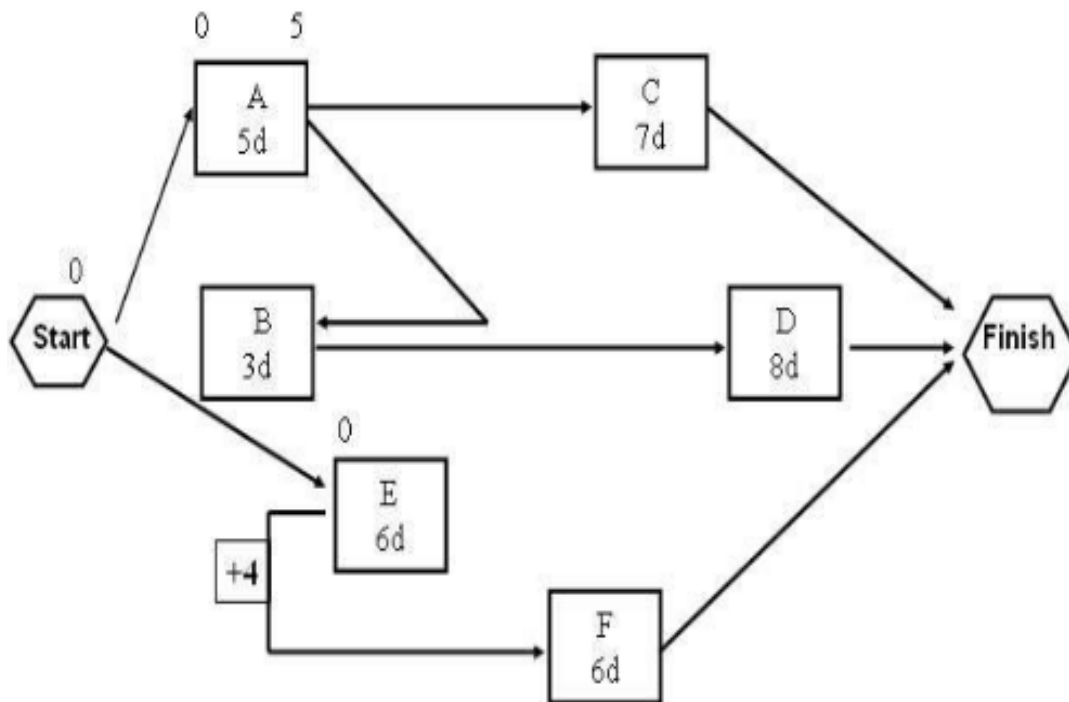

Выберите один ответ:

- E,F
- A,B,D
- A,B,C
- A,C

Вопрос 16/199

PE 013: _____ is a type of bid document used to solicit proposals from prospective sellers of products or services:

Выберите один ответ:

- Contract
- Statement of Work (SOW)
- Request for Quotation (RFQ)
- Request for Proposal (RFP)

Вопрос 17/199

COME 701: A project manager should try to dedicate a primary focus to:

Выберите один ответ:

- Communicating authorized changes to senior management and key stakeholders
- Formally documenting all changes
- Managing changes immediately as they surface
- Preventing unnecessary changes

Вопрос 18/199

COSM 519: In EVM (Earned Value Management) which of the following statements is NOT correct?

Выберите один ответ:

- At the completion of a project which is behind schedule, the SPI (Schedule Performance Index) is less than one
- measures schedule performance not in units of time, but rather in cost
- At the completion of a project which is behind schedule, SV (Schedule Variance) is equal to zero.
- SPI (Schedule Performance Index) will not differentiate between late tasks on the critical path and late tasks not on the critical path

Вопрос 19/199

HE 616: Group brainstorming encourages all of the following EXCEPT:

Выберите один ответ:

- Uninhibited verbalization
- Analysis of alternatives
- Team building
- Convergent thinking

Вопрос 20/199

TP 359: A work package could be completed in _____ days in the optimistic case, and in 220 days in the pessimistic case, 100 days is the most probabilistic estimate. 110 is the PERT estimate for the expected duration of that work package.

Выберите один ответ:

- 110
- 40
- 120
- 240

Вопрос 21/199

HE 629: According to Tuckman, the 4 stages of team development are:

Выберите один ответ:

- Enthusiasm, Hope, Panic, Solution
- Conflict, Building, Winning, Concluding
- Forming, Storming, Norming, Performing

- Direction, Motivation, Cooperation, Collaboration

Вопрос 22/199

RM 809: As a risk response "Removing a potential troublesome resource from the project" falls under the category:

Выберите один ответ:

- Ignore
- Mitigate
- Transfer
- Avoid

Вопрос 23/199

XX 002: A new seller invites you for a hot air balloon tour with your wife and your family. You should:

Выберите один ответ:

- Consider which gift you could give him on your next visit
- Accept since you did not personally asked for the tour
- Close your relationship with the supplier
- Refuse kindly

Вопрос 24/199

QM 015: An example of "cost of non conformance" would be:

Выберите один ответ:

- Inspection/Quality audits
- Process validation
- Process control
- Warranty repairs or service

Вопрос 25/199

QP 033: Philip Crosby`s concept is based on all the following EXCEPT:

Выберите один ответ:

- Absolute quality is not achievable
- The measurement of quality is the price of non-conformance
- The system of quality is prevention

- The performance standard is zero defects

Вопрос 26/199

COSM 509: $EAC=AC + ((BAC-EV)/CPI \times SPI)$ is used when the assumption is that:

Выберите один ответ:

- ETC not measurable
- ETC (Estimate to Complete) work performed at the budget rate
- ETC work performed at the present CPI
- ETC considering both SPI and CPI

Вопрос 27/199

644: Your preferred resource is not available at the time needed. What is the best thing to do?

Выберите один ответ:

- Contact the HR department
- Assess your alternatives
- Negotiate with management to get the resource
- Use reserves to increase resources assigned to those tasks

Вопрос 28/199

XX 016: You found a mistake in your colleague's report that was already sent out to key stakeholders. Your next step would be:

Выберите один ответ:

- Do nothing as he is not reporting to you
- Be logical about informing people of what they need to know so that corrections can be made and the project can move on
- Keep quiet as every body makes mistakes one day
- Report the error to his boss

Вопрос 29/199

RP 854: Which statement is NOT correct concerning expected value?

Выберите один ответ:

- Expected value is the most likely value
- It is unwise for decisions to be made solely on the basis of expected values because business decisions are rarely repeated
- Expected values should be supplemented with the measures of dispersion

- It is unwise for decisions to be made solely on the basis of expected values because business managers are unlikely to be neutral towards risk

Вопрос 30/199

IP 95: Integration is the primary role of

Выберите один ответ:

- The sponsor
- The configuration manager
- The project team
- The project manager

Вопрос 31/199

II 10: The most effective way to accelerate the project integration process is:

Выберите один ответ:

- Through frequent periodic team communications
- By assigning specific responsibilities to each project employee
- By having the sponsor apply direct influence on the project team
- To use crisis periods to reinforce integration activities

Вопрос 32/199

SP 259: The scope statement usually includes all of the following EXCEPT:

Выберите один ответ:

- Project exclusions
- Risk categories
- Product acceptance criteria
- Project constraints

Вопрос 33/199

HE 638: Which statement related to Conflict Management is NOT correct?

Выберите один ответ:

- Conflict resolution should focus on the past (causes) , not on the future
- Conflict is a team issue
- Openness resolves conflict
- Conflict is natural and forces a search for alternatives

Вопрос 34/199

COME 710: Which of the following are the most common categories of project reports?

Выберите один ответ:

- Profitability, status, and exception
- Status, SWOT analysis
- Trend, Profitability
- Status, trend, variance, and exception

Вопрос 35/199

XX 011: The purpose of the Code of Ethics and Professional Conduct for project managers is to:

Выберите один ответ:

- Make sure that project management is recognized as a full profession within the communities
- Promote the project manager's career
- Instill confidence in the project management profession and to help an individual become a better practitioner
- Make sure that all projects are completed in time, budget, and scope

Вопрос 36/199

COMM 720: How much time does the typical project manager spend communicating both formally and informally?

Выберите один ответ:

- 40-60%.
- 60-80%.
- 75-90%.
- 50-70%.

Вопрос 37/199

II 94: The PM is busy implementing an accounting package; he cannot get the chief accountant, a SME (Subject Matter Expert), the amount of time required to finish the draft of the test cases. The accountant is too busy completing his daily work. The project manager does not decide on the work assignments for the accountant. This situation is an example of a _____ organization.

Выберите один ответ:

- Functional
- Tight matrix

- Balanced matrix
- Uncontrolled

Вопрос 38/199

COME 709: The Project Charter is an input to the following processes EXCEPT:

Выберите один ответ:

- Manage Stakeholders Expectations
- Identify Stakeholders
- Define Scope
- Collect Requirements

Вопрос 39/199

COMI 714: Individuals and organizations who are involved in or may be affected by project activities are:

Выберите один ответ:

- Team members
- Participants
- Stakeholders
- Concerned persons

Вопрос 40/199

RP 877: In regards to risk response, "Mitigation" consists of

Выберите один ответ:

- Transferring the risk by buying insurance
- Reducing the expected monetary value of a risk event by reducing the probability of occurrence or reducing the risk event value.
- Eliminating a specific threat, usually by eliminating the cause
- Developing a contingency plan should the risk occur

Вопрос 41/199

. RP 880: In risk management using EMV (Expected Monetary Value) requires to be risk neutral because all of these reasons EXCEPT:

Выберите один ответ:

- EMV does not consider best case
- Because 50% chance to get 200\$ is different from 100% chance to get 100\$.
- EMV does not consider worst case

- EMV does not consider the range between worse and best case

Вопрос 42/199

SM 203 : A change request has just been raised. The first thing which the Project manager should do is:

Выберите один ответ:

- Document the request
- Assess the impact on the cost
- Assess the impact on the schedule
- Assess the impact on the objective

Вопрос 43/199

COSM 505: An unfavorable SPI (Schedule performance Index) could originate from all the following EXCEPT:

Выберите один ответ:

- ASPI greater than 1
- Poor estimation
- Poor planning
- Actual cost greater than expected

Вопрос 44/199

. TP 436: Based on the following network, the Project Manager would conclude that the total float for D is:

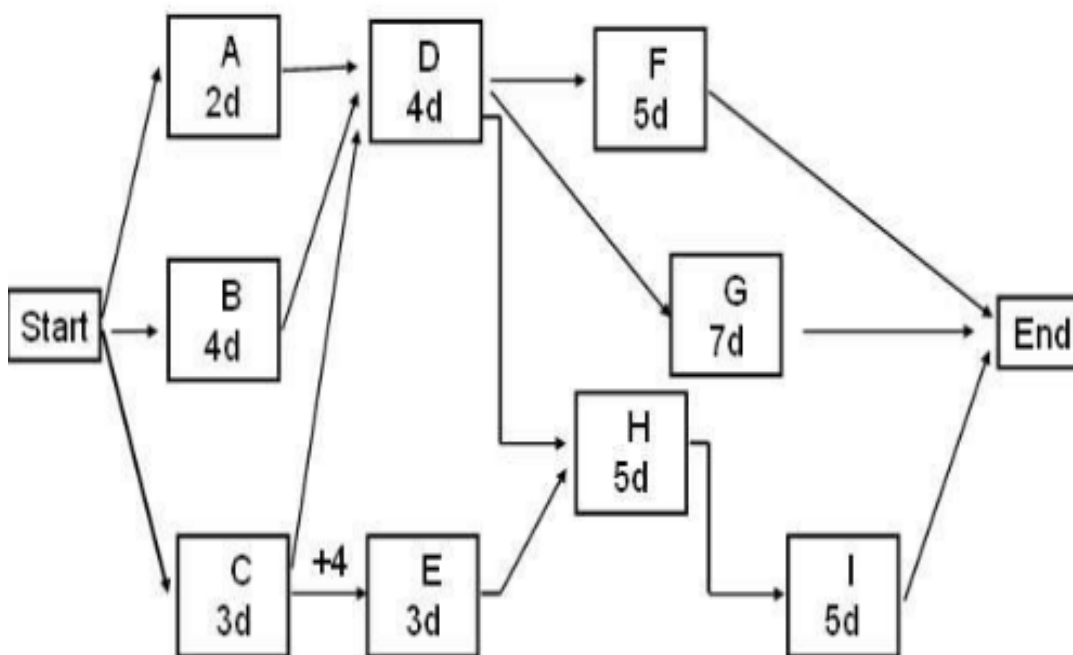

Выберите один ответ:

- 4
- 3
- 6
- 2

Вопрос 45/199

SM 204 : A functional manager wants to make a change to the time associated with a task, but there is not enough reserve to accommodate the change. Who should authorize the change?

Выберите один ответ:

- The team member performing the work
- The functional manager
- The project manager
- Senior management

Вопрос 46/199

1114: What is the net present value of an annual income flow of \$1600 at a money discount of 10% over the next 3 years?

Выберите один ответ:

- 1322,31
- 3978,96
- 1202,10
- 4958,23

Вопрос 47/199

XX 004: Mother project manager is definitely spreading rumors that you falsified your last status report. You would best:

Выберите один ответ:

- Hit back with your own rumors
- Request a face to face meeting with him even if he is superior in the company's hierarchy
- Report the issue to his boss,
- Ignore the rumor

Вопрос 48/199

HP 661: Theory X and Y was developed by:

Выберите один ответ:

- McGregor
- Maslow
- Gantt
- Gold ratt

Вопрос 49/199

TP 414: Which statement is NOT correct regarding "negative float"?

Выберите один ответ:

- Negative float can originate from external dependency
- Negative float indicates that the schedule is not valid
- Negative float exists when Cost Variance is negative..
- Negative float should not be an issue since it can be removed by increasing the lag

Вопрос 50/199

COMP 737: Which statement is NOT correct concerning the Communications management plan?

Выберите один ответ:

- It an output to "Plan Communications".
- It is an input to "Plan Risk Management".
- It usually provides a glossary of common terminology
- It is an input to the process "Develop Project Charter"

Вопрос 51/199

HE 636: Which of the following roles is the least appropriate for the project manager?

Выберите один ответ:

- Technical consultant
- Leader
- Facilitator
- Motivator

Вопрос 52/199

COMP 726: In negotiations, what is a fait accompli tactic?

Выберите один ответ:

- Completing a phase of work before the other side is ready

- Promising that a requirement will be completed before it is due
- Claiming an issue has already been decided and therefore cannot be changed.
- Pretending to accept the other side's offer

Вопрос 53/199

HP 653: In theory X, which statement is meant to be correct?

Выберите один ответ:

- Absenteeism is tied to poor salary
- Do not expect a Mr. X to come and save your project.
- Workers are inherently unmotivated and need strong guidance
- X measures the degree of commitment of a team

Вопрос 54/199

QM 021: Which of the following is NOT considered a cost of non-conformance to quality?

Выберите один ответ:

- Expediting
- Process control
- Scrap
- Rework

Вопрос 55/199

IM 12: Configuration control is focused on the specification of both _____ while change control is focused on identifying, documenting and controlling changes to the _____ and the project baselines

Выберите один ответ:

- Requirements and deliverables, project
- Deliverables and the processes, requirements
- Requirements and scope, project
- Deliverables and the processes, project

Вопрос 56/199

TM 310: Which statement is NOT correct regarding EVM (Earned Value Management)?

Выберите один ответ:

- EVM typically would not assume that project accounting and project network schedule management are prerequisites.

- EVM is often perceived to be inapplicable to discovery-driven or Agile software development projects
- EVM has no provision to measure project quality
- Traditional EVM is not ideally intended for non-discrete (continuous) effort

Вопрос 57/199

RM 912: A _____ person would consider 20% chance of winning \$1 million exactly equal to \$200,000 (or a 20% chance of losing \$1 million to be exactly equal to losing \$200,000)

Выберите один ответ:

- Risk averse
- Gambling
- Risk neutral
- Risk seeking

Вопрос 58/199

COSM 528: In your project the following data is available: AC (Actual cost) = \$10,000 ; CPI (Cost Performance Index) = 0.8; BAC = \$20,000. Assuming that the CPI can now be representative for the rest of the project, what will the EAC (Estimate at Completion) be?

Выберите один ответ:

- 22 000\$
- 25 000\$
- 24 000\$
- 20 000\$

Вопрос 59/199

SP 231: A clear definition of the customer's needs serves as the direct basis for which of the following?

Выберите один ответ:

- Functional requirement
- Project cost estimate
- WBS
- Project charter

Вопрос 60/199

RM 842: One of your team members comes back to you with a new risk which was discussed in his group. The first thing which you should do is:

Выберите один ответ:

- Mitigate the risk
- Document the risk
- Avoid the risk
- Ignore the origin

Вопрос 61/199

RP 810: A separately planned quantity used to allow for future situations which are impossible to predict is _____ .

Выберите один ответ:

- For the known unknowns
- Concerned with pure risks
- Management Reserve
- Not quantifiable

Вопрос 62/199

321: Which statement is NOT correct?

Выберите один ответ:

- The Total Float of a path is less than the combined "Free Float" values of all activities in a Path
- An activity on critical path has "Zero free float", but an activity that has zero free float may not be on the critical path
- Total float is the amount of time that a task in a project network can be delayed without causing a delay to project completion date.
- Free float is the amount of time that a task in a project network can be delayed without causing a delay to subsequent tasks

Вопрос 63/199

QP 002: Regarding quality which statement is the NOT correct?

Выберите один ответ:

- "Right first time" means that mistakes should be eliminated
- Goods with low prices can be considered quality items if they meet a market need
- Quality Assurance is a guarantee for the production of quality products
- "Fit for purpose" means that the product should be suitable for the intended

Вопрос 64/199

005: All the following statement related to Standards and Regulations are correct EXCEPT:

Выберите один ответ:

- Standards after widespread adoption may become de facto regulations
- Regulations are mandatory but Standards are not mandatory
- Standard is a document approved by a recognized body - there can be multiple standards for one product
- The influence of standards and regulations for a project is always known

Вопрос 65/199

PP 015: Which of the following contracts should you use for projects that have a high degree of uncertainty and require a large investment early in the project life cycle?

Выберите один ответ:

- Cost reimbursable
- Unit price
- Fixed Price
- Lump sum

Вопрос 66/199

PP 003: A formal invitation to submit a price for goods and/or services as specified is called:

Выберите один ответ:

- Intention to bid
- RFP (Request for Proposal).
- Invitation for bid
- RFQ (Request for Quote).

Вопрос 67/199

PE 047: In Purchasing, the seller is reimbursed for allowable costs of performing the contract and receives as profit a fixed fee payment based on the percentage of the estimated costs; the fixed fee does not vary with the actual costs unless the scope of work changes. The type of contract describes a _____ contract.

Выберите один ответ:

- Cost-Plus-Percentage of Cost (CPPC).
- Cost-Plus-Incentive Fee (CPIF).
- Cost-Plus-Award-Fee (CPAF).
- Cost-Plus-Fixed Fee (CPFF).

Вопрос 68/199

RP 813: The inherent chances for both profit or loss associated with a particular endeavor are:

Выберите один ответ:

- Business Risk
- Absolute Risk
- Normal Risk
- Pure Risk

Вопрос 69/199

SP 257: The Requirement Management plan is _____ to the process "Collect Requirements"

Выберите один ответ:

- An audit mechanism
- An output
- A tool
- An input

Вопрос 70/199

XX 022: Your company policy allows to gift exchange with customer within certain limit. By mistake, you have given a gift to the customer's representative already which is beyond the limit mentioned in your company policy. What would your next step be?

Выберите один ответ:

- Ask your customer to give you a gift which has the same value
- Ask your customer to return the gift
- Do nothing as it is too late
- Contact your company's senior management and ask for assistance

Вопрос 71/199

SM 209: The project sponsor should not accept that the Project manager re-baselines the project because of:

Выберите один ответ:

- Change requests
- Scope changes
- Necessity to be in line with the original plan
- Official decrease in scope

Вопрос 72/199

COSP 579: The measure of progress achieved compared to progress planned on a project is called:

Выберите один ответ:

- Cost performance index
- To complete performance index
- Schedule performance index
- Budgeted cost of work performed

Вопрос 73/199

QM 024: Pareto Analysis, cause and effect diagrams and flow charts are used in quality

Выберите один ответ:

- Verification
- Planning
- Assurance
- Control

Вопрос 74/199

COME 706: The advantages of verbal communication include all the following EXCEPT:

Выберите один ответ:

- Timely exchange of information
- Rapid feedback
- Technical jargon does not need heavy explanations
- Immediate synthesis of message

Вопрос 75/199

RP 803: A workaround is:

Выберите один ответ:

- A planned response to negative risk events
- An unplanned response to negative risk events
- An unplanned response to positive risk events
- A planned response to positive risk events

Вопрос 76/199

PP 023: In order to get an award, a contractor may submit a bid that is unrealistically low. This is called a(n):

Выберите один ответ:

- Unfair practice
- Dispute
- Invitation for Bid
- Lowball

Вопрос 77/199

TP 429: Using the following network diagram as a project manager you could delay the activity B by ___ days from its early start without delaying the project

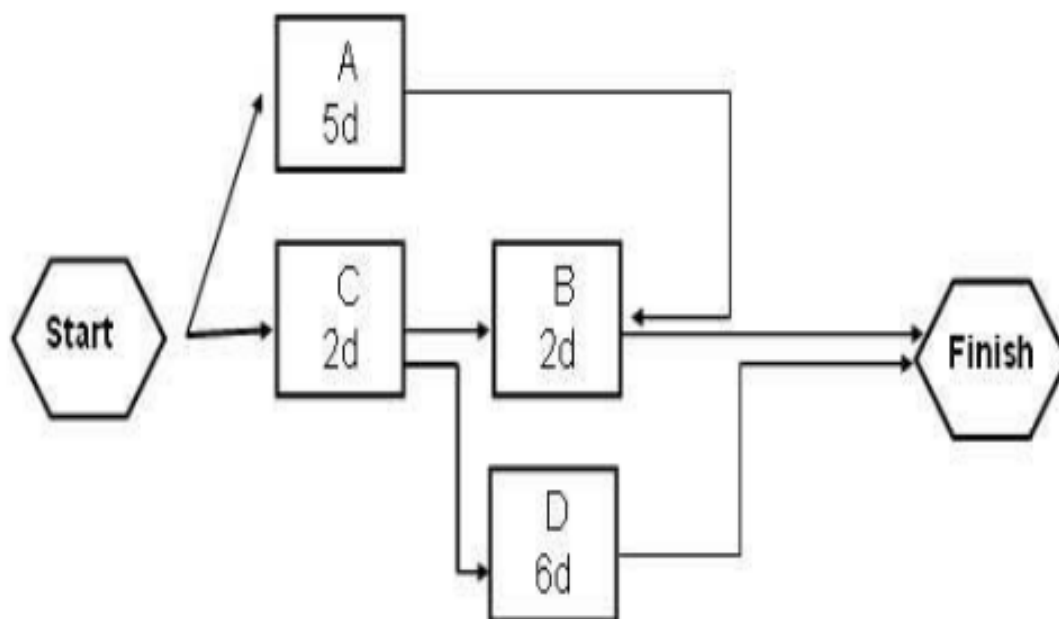

Выберите один ответ:

- 3
- 1
- 2
- 4

Вопрос 78/199

. RP 873: The independence of two events in which the occurrence of one is NOT related to the occurrence of the other is called:

Выберите один ответ:

- Independent probability

- Statistical probability
- Event phenomenon
- Statistical independence

Вопрос 79/199

II 74: Which of the following is best for handling cross-functional project needs for a large, complex project?

Выберите один ответ:

- A project coordinator
- A functional organization
- A strong matrix organization
- A vertical organization

Вопрос 80/199

QM 047: Special-cause variation is characterised by:

Выберите один ответ:

- New, unanticipated, emergent or previously neglected phenomena within the system.
- Variation predictable probabilistically probability.
- Irregular variation within an historical experience base.
- Phenomena constantly active within the system.

Вопрос 81/199

SP 280: The detailed project scope statement includes, either directly, or by reference, all the following EXCEPT:

Выберите один ответ:

- Product scope description
- Work Breakdown Structure
- Product acceptance criteria
- Project exclusions

Вопрос 82/199

QM 026: You are in charge of developing a new product for an organization. Your quality metrics are based on the 80th percentile of each of the last three products developed. This is an example of:

Выберите один ответ:

- Benchmarking.

- Operational definitions.
- Statistical sampling.
- Metrics.

Вопрос 83/199

COSM 514: EVM (Earned Value Management) involves calculating all of the following values EXCEPT:

Выберите один ответ:

- Cost performance index.
- Cost variance.
- Sunk cost.
- Estimate at completion.

Вопрос 84/199

COSM 591: Which statement is NOT true concerning EVM (Earned Value Management)?

Выберите один ответ:

- At the end of the project the Earned Value equals the Planned Value since all the scheduled work is done.
- Work has value equal to its budget.
- At the beginning of the project the Earned Value is zero.
- Work has value equal to what was spent to complete it (Actual Cost)

Вопрос 85/199

PE 028: Bidder Conferences are meetings with _____ prospective sellers _____ submittal of a bid or proposal.

Выберите один ответ:

- selected, prior to
- the cheapest, after
- all, prior to
- selected, after

Вопрос 86/199

RP 874 A risk response which involves eliminating the cause of a threat is called:

Выберите один ответ:

- Transfer.
- Deflection.

- Avoidance.
- Mitigation.

Вопрос 87/199

TM 318: You get the following report. If there was one task to crash, you would choose:

Task	Early Finish	Late Finish
W	10	14
X	10	17
Y	5	10
Z	17	9

Выберите один ответ:

- Y
- Z
- W
- X

Вопрос 88/199

HE 610: A project manager has been working on a project for three months with the same team yet the team still shows a lack of support for the project. The last thing for the project manager to do would be to?

Выберите один ответ:

- Re-evaluate the effectiveness of the reward system the project manager has put in place.
- Contact the HR department to look for substitutes.
- Talk to each team member's boss.
- Tell the team he needs its support.

Вопрос 89/199

HE 642: Your authority is derived from the fact that you are a vice president. This situation depicts it as a _____ authority.

Выберите один ответ:

- Reward.
- Bureaucratic.
- Referent.
- Legitimate and formal.

Вопрос 90/199

PP 032: A contract where the seller agrees to perform a service or furnish supplies at the established contract price is called:

Выберите один ответ:

- Fixed Price-Plus-Incentive Fee (FPI)
- Cost-Plus-Incentive Fee (CPIF).
- Cost-Plus-Fixed Fee (CPFF).
- Firm-Fixed Price (FFP).

Вопрос 91/199

TM 444: As tasks are rescheduled without a new baseline to an earlier date than the plan start date, the SPI (Schedule Performance Index) tends to

Выберите один ответ:

- Become infinite
- Become negative
- Converge to 1
- Converge to 0

Вопрос 92/199

1M 118: Expert judgment is a Tools and Techniques for all the following processes EXCEPT:

Выберите один ответ:

- Develop project Management Plan
- Close Project or Phase.
- Develop Project Charter
- Create WBS

Вопрос 93/199

COME 703: In communication management, to translate the message back into meaningful thoughts or ideas is

Выберите один ответ:

- Decoding
- Understanding
- Comprehending
- Receiving

Вопрос 94/199

PP 042: In an environment where the buyer can only describe what is needed but not what to do, the most suitable type of contract would be

Выберите один ответ:

- Lump sum
- Cost reimbursable.
- Fix price.
- POC (Percentage of completion)

Вопрос 95/199

HE 603: After the kickoff meeting, two team members engage in a casual conversation about the project objectives and deliverables. It is clear they heard different messages during the meeting. One member is so adamant that the other member gives up arguing the point. After talking to the project manager, the second member confirms that the first member is mistaken. At this point, what is the BEST course of action?

Выберите один ответ:

- Remove the project manager.
- The second team member should send the other team member an e-mail describing what he discovered.
- At the next project meeting, the project manager should spend time reviewing a documented scope statement with the goal of identifying this and other false assumptions
- At the next project meeting, the team member should ask the mistaken team member to describe his interpretation so the project manager can get everyone on the same page

Вопрос 96/199

QM 007: When a product or service completely meets a customer requirement then which of the following is true?

Выберите один ответ:

- Quality is achieved.
- The cost of quality is high
- The project manager did too much
- The customer pays the minimum price.

Вопрос 97/199

HP 652: Herzberg came up with a theory which:

Выберите один ответ:

- Is called the X and Y theory.

- Stated that people are motivated by factors that deal with the work and the satisfaction that people get by performing the actual functions of their jobs.
- Excludes a Z theory
- Includes "hygiene" factors.

Вопрос 98/199

QP 018: All the followings belong To the Major Cost Categories of Quality EXCEPT:

Выберите один ответ:

- Prevention Cost
- Appraisal Cost.
- Internal Failure Cost
- Investment Cost.

Вопрос 99/199

PP 037: Which of the following is NOT taken into account during the Procurement Planning Process?

Выберите один ответ:

- The accuracy of the time estimates
- How to procure and how much to procure.
- Whether to procure.
- What and when to procure

Вопрос 100/199

HE 607: _____ is least likely to result in a project team with a strong commitment to quality

Выберите один ответ:

- High staff turnover.
- Strong team commitment to reach the objectives of the project.
- Social events.
- Clear defined goals.

Вопрос 101/199

PP 010: A Research and Development project would be best managed using which of the following contracts?

Выберите один ответ:

- Cost reimbursable.

- Lump sum.
- Fix price
- Percentage of Completion (POC).

Вопрос 102/199

PP 056: Together with your team you have reviewed the potential sellers for your project. This activity matches the process

Выберите один ответ:

- Administer Procurements.
- Select Sellers.
- Plan Procurements
- Conduct Procurments

Вопрос 103/199

PP 038: Which is not a consideration in a make or buy decision?

Выберите один ответ:

- Existence of sufficient administrative I technical personnel.
- Sales volume.
- Political and social factors with the organization.
- Cost factors

Вопрос 104/199

SP 214: Scope verification differs from quality control in that scope verification is primarily concerned with _____ of the deliverables, while quality control is primarily concerned with _____ of the deliverables.

Выберите один ответ:

- Acceptance, correctness.
- Correctness, acceptance
- Acceptance, safety.
- Correctness, safety.

Вопрос 105/199

COSM 529: Potential causes of unfavorable (-) cost performance could be all of the following EXCEPT:

Выберите один ответ:

- Overhead Rate Decreases.
- Unfavorable Market Fluctuations in the Cost Labor or Material.
- Work more complex than anticipated.
- Unclear Requirements

Вопрос 106/199

1113: Which statement is NOT correct?

Выберите один ответ:

- The project manager should be assigned at least prior to the start of project plan execution.
- The project manager should be assigned preferably before much project planning has been done.
- The project manager should be assigned only once the project charter is signed.
- The project manager should be assigned as early in the project as feasible.

Вопрос 107/199

SM 210 : The traditional triple constraints describe the conflicts between:

Выберите один ответ:

- Good, cheap, and quick
- Time, Cost, and Scope
- Quality, time, and scope
- Resource, Cost, and Time.

Вопрос 108/199

XX 014: You are puffing together a proposal for a project. The salesperson decides to "doctor" the figures so that the project be won. Your response should be:

Выберите один ответ:

- Tell him that it is not fair.
- Report the matter to your superior, or to the project sponsor.
- Close your eyes as the sales guy needs his commission.
- Help him since you will be in charge of the project.

Вопрос 109/199

1M 86: If there is a need to know the content of an old version of a product baseline, what would be the first system to use?

Выберите один ответ:

- A configuration management system
- Project charter.
- Scope baseline.
- Requirements documentation

Вопрос 110/199

COMP 733: The sender of a message is responsible for:

Выберите один ответ:

- Scheduling communication exchange.
- Making sure that the information is clear and complete.
- Presenting the message in the most agreeable manner.
- Ensuring the receiver agrees with the message.

Вопрос 111/199

QE 010: The process Perform Quality Assurance belongs to which of the following process groups?

Выберите один ответ:

- Execution.
- Monitoring and Controlling
- Planning.
- Closing.

Вопрос 112/199

XX 009: The concept of Project Management Ethics usually revolves around the below EXCEPT:

Выберите один ответ:

- Priority: Always keep in mind the highest rank of the project objectives above all other values.
- Honesty: Be honest, do not mislead others, and do not engage in deception
- Integrity: Have some good values, and respect your job.
- Truth: Always say the truth when communicating with stakeholders/team members.

Вопрос 113/199

XX 24: Your close colleague with whom you graduated is found to be doing something illegal in your company. Only you know about it, and reporting it would mean losing the trust or friendship of your friend and co-worker. What would you do in this situation?

Выберите один ответ:

- Report to higher authorities.
- Call the Police
- Keep quiet as friendship is one of the most noble values.
- Confront your friend yourself: you must help a friend in need.

Вопрос 114/199

SP 290: All the following rules concerning the WBS are true EXCEPT:

Выберите один ответ:

- The work represented by the activities in each work package must add up to 100% of the work necessary to complete the work package The work represented by the activities in each work package must add up to 100% of the work necessary to complete the work package.
- It is important that there is no overlap in scope definition between two elements of a Work Breakdown Structure.
- The WBS includes 100% of the work defined by the project scope and captures all deliverables — internal, external, interim — in terms of the work to be completed, excluding project management
- The WBS should not include any work that falls outside the actual scope of the project, that is, it cannot include more than 100% of the work.

Вопрос 115/199

II 3: What is the expected value of a project where the probability to make €40 000 of profit is 0,05; to make €60 000 of profit is 0,10; to make €80 000 of profit is 0,40; to make €100 000 of profit is 0,25; and to make €120 000 of profit is 20 percent?

Выберите один ответ:

- €85 000
- €89 000
- €120 000
- €80 000

Вопрос 116/199

II 78: _____ descrthes the project life cycle:

Выберите один ответ:

- What you need to do to manage the project.
- Initiating, planning, executing, monitoring, and closing.
- What you need to do to perform the work.

- Project management process.

Вопрос 117/199

RP: 910 Your supplier was late; it cost you 200 \$. Consequently you now have a 50 percent probability that you will deliver after the deadline: Late delivery would result in a \$100 loss, the expected monetary value of failing is:

Выберите один ответ:

- 75 \$
- 50 \$
- 250\$
- 100\$

Вопрос 118/199

COSP 563: _____ is the process of developing an approximation of the monetary resources needed to complete project activities.

Выберите один ответ:

- Determine budget.
- Determine costs
- Estimate costs.
- Evaluate budget.

Вопрос 119/199

RP 833: Which of the following statements concerning pure risk is NOT correct?

Выберите один ответ:

- Pure risks are also called insurable risks.
- Pure risk can typically be covered by an insurance policy.
- Pure risks are risks which can only have a negative impact.
- An example of pure risk would be the risk you take by accepting a fix price contract as a supplier

Вопрос 120/199

COSM 513: EVM (Earned Value Management) can be classified as:

Выберите один ответ:

- A scheduling tool.
- A performance reporting tool.

- A planning tool.
- An accounting tool.

Вопрос 121/199

II 89: All the following are examples of Organizational Process Assets EXCEPT:

Выберите один ответ:

- Procedures on risk control.
- Project war room.
- Financial controls.
- Standardized guidelines.

Вопрос 122/199

11108: Each project phase is typically:

Выберите один ответ:

- Ideally no longer than 80 hours of work.
- Marked by completion of one or more deliverables.
- In a FS (Finish Start) sequence with the next phase or with the end mark of the project.
- Marked by a milestone

Вопрос 123/199

TP 364: If you have to wait for a delivery for 5 days after having put the order. You will use a in the relationship between ordering and delivery.

Выберите один ответ:

- Delay.
- Lag.
- Lead.
- Log.

Вопрос 124/199

SP 216: Collect requirements is the process of defining and documenting _____ to meet the project objectives.

Выберите один ответ:

- Detailed requirements.
- Users requirements.
- Stakeholders' needs

- Technical requirements.

Вопрос 125/199

RP 837: Because an important meeting could be threatened by air travel disruption, a risk owner decided to organize a telephone conference instead. This response falls under the category

Выберите один ответ:

- Alternate.
- Avoid.
- Transfer.
- Accept.

Вопрос 126/199

COSP 577: The graphical display of the cumulative Planned Cost against time is called

Выберите один ответ:

- The S-Curve.
- The budget curve.
- The X-Curve.
- The PCC

Вопрос 127/199

HP 656: McGregor's Y theory implies that staff:

Выберите один ответ:

- need to be controlled in order to obtain good performance.
- are inherently motivated and ambitious.
- would avoid work.
- work only well if the financial reward is good.

Вопрос 128/199

SP 270: Which of the following statements is NOT true?

Выберите один ответ:

- Work breakdown structure(updates) is an output of "Control Scope".
- WBS Dictionary is an output of the process "Define Scope".
- Work Performance information is an input to "Control Scope".
- Requested changes is an output of "Verify Scope".

Вопрос 129/199

TM 311: Which statement is correct?

Выберите один ответ:

- TCPI (To Complete Schedule Performance Index) value less than 1 indicates project team can be lenient in utilizing the remaining time allocated to the project.
- TCPI (To Complete Schedule Performance Index) with a value above 1 indicates project team needs to work harder in utilizing the remaining time allocated to the project.
- SPI (Schedule Performance Index) with a value less than 1 indicates project team is very efficient in utilizing the time allocated to the project.
- To Complete Schedule Performance Index, is $TCPI = \frac{\text{Total Budget} - EV}{\text{Total Budget} - PV}$.

Вопрос 130/199

TP 334: A, B, C, and D are the four activities of one same project. The duration of A, and D is 10 weeks; the duration of C, and B is 15 weeks. The project starts with A and C in parallel- B can only start once A is complete; D can only start once C and B are both complete. The project is complete when all the activities are complete. If the activity C and B were performed by the same resource, which statement would NOT be correct?

Выберите один ответ:

- A delay of 15 days on activity A would delay the project.
- The additional milestone activity which would indicate the end of the project is not on the critical path.
- A delay of 10 days on activity A would delay the project.
- Any delay on A would delay the project because A is on the critical path.

Вопрос 131/199

RP 865: Who would be best qualified to analyze risks?

Выберите один ответ:

- The sponsor.
- The project manager.
- The project team.
- The PMO (Project Management Office)

Вопрос 132/199

SP 215: A formally constituted group of stakeholders responsible for approving or rejecting changes to the project baselines is called

Выберите один ответ:

- WBS (work breakdown structure)

- CCB (change control board)
- CBS (organizational breakdown structure)
- Highest Authority.

Вопрос 133/199

TP 323: "Compressing the project schedule by overlapping activities that would normally be done in sequence" is called:

Выберите один ответ:

- Rushing.
- Sweating.
- Fast tracking.
- Crashing.

Вопрос 134/199

COSP 665: Which statement related to Three Point Estimate is NOT correct?

Выберите один ответ:

- It uses, among other inputs, the pessimistic estimate.
- It uses, among other inputs, the optimistic estimate.
- The accuracy of single point estimate can be improved by considering estimation uncertainty and risk.
- It uses, among other inputs, the expected value.

Вопрос 135/199

TM 315: You get the following report. Your conclusion is:

Task	Early Finish	Late Finish
W	10	14
X	10	17
Y	5	10
Z	17	9

Выберите один ответ:

- Everything is fine.
- Z is behind schedule
- X is behind schedule
- W is behind schedule

Вопрос 136/199

XX 010: The four values which have been identified as being important to project managers around the globe are:

Выберите один ответ:

- Leadership, respect, fairness , and honesty.
- Responsibility, respect, fairness, and honesty
- Leadership, charisma, sense of purpose, and devotion.
- Accountability, respect, fairness, and devotion.

Вопрос 137/199

COME 708: "Manage Stakeholders Expectations" means:

Выберите один ответ:

- Control the scope when items not in the WBS are required.
- Make stakeholders feel their needs and concerns are being considered.
- Do not exceed what has been promised
- Make sure that Stakeholders requirements are realistic.

Вопрос 138/199

COSP 590: Which statement is true concerning estimations established by comparing projects that may be similar to some degree.

Выберите один ответ:

- It is not very useful since no two projects are similar.
- It is a boftom up estimate
- Since projects are unique, one should avoid this type of approach.
- It is called "Analogous Estimate".

Вопрос 139/199

COSM 526: In EVM (Earned Value Management) _____ is the baseline for performance:

Выберите один ответ:

- EV (Earned Value)
- EAC (Estimate at Completion)
- PV (Planned Value)
- ETC (Estimate to Complete)

Вопрос 140/199

COMI 716: The success of a project depends on several factors, including time, cost and scope control. The success of any project depends primarily on:

Выберите один ответ:

- Exceeding customer requirements.
- Exceeding customer requirements through gold plating.
- Having the UAT (User Acceptance Test) signed.
- Customer satisfaction.

Вопрос 141/199

PP 007: When invitations for bid are issued to the sellers, the bids should be submitted in a standard format because

Выберите один ответ:

- It gives the greatest assurance that all items are covered and the proposals can be evaluated in a uniform manner.
- The government has specified that proposals must meet the requirements of contract law and this assures the incorporation
- The owner (buyer) has a format that he routinely uses and wants to force the contractors to meet his requirements.
- The Association of Contractors has prescribed the format to which all bidders must comply to meet a legal proposal.

Вопрос 142/199

PM 028: In procurement, which of the following is true concerning sellers evaluation criteria?

Выберите один ответ:

- Must be limited to purchase price
- Can be objective or subjective.
- It is part of the proposal.
- Must be known by the sellers.

Вопрос 143/199

HE 605: One theory states that there are five stages of development that teams may go through. This theory originated with:

Выберите один ответ:

- Maslow.
- Mc. Gregor.
- Tuckman.

- Gantt.

Вопрос 144/199

HP 664: Which of the following is NOT a management style?

Выберите один ответ:

- Natural: guided by instinct.
- Laissez faire: nobody is in charge.
- Democratic: participative.
- Autocratic: tight control.

Вопрос 145/199

QP 012: Top management's overall intentions and direction with regard to quality is formally expressed in the:

Выберите один ответ:

- Quality Statement.
- Quality Policy
- Quality Plan.
- Quality Assurance.

Вопрос 146/199

PE 065: On a cost plus fixed fee contract the agreed upon fee is 50k\$, and the actual cost is 250k\$. The probability for the seller to have a deadline penalty is 25%. The fee is:

Выберите один ответ:

- 200k\$
- 250k\$
- Ok
- 50k\$

Вопрос 147/199

RM 870: When should a risk be avoided?

Выберите один ответ:

- When the risk event is unacceptable -- generally one with a very high probability of occurrence and high impact.
- When the risk event has a low probability of occurrence and low impact
- A risk event can never be avoided.
- When it can be transferred by purchasing insurance.

Вопрос 148/199

COMP 736: The three major types of communication are:

Выберите один ответ:

- Verbal, formal documentation, informal documentation.
- Verbal, written, and electronic.
- Written, verbal, and non-verbal.
- Verbal, written, and graphic

Вопрос 149/199

QM 044: The process Perform Quality Control belongs to which of the following process groups?

Выберите один ответ:

- Planning.
- Execution.
- Quality Control.
- Monitoring and Control.

Вопрос 150/199

RP 878: Contingency reserves are normally:

Выберите один ответ:

- Included in the project's cost and schedule baselines.
- Used to control changes to the project budget.
- Reserved to management.
- Equivalent to "padding".

Вопрос 151/199

TP 369: In the critical chain method, the buffer placed at the end of the project is called:

Выберите один ответ:

- Project buffer.
- Padding.
- Safety chain buffer.
- End buffer.

Вопрос 152/199

COMP 722: is one of the most important skills a project manager should have.

Выберите один ответ:

- Problem-solving skills.
- Negotiation skills.
- Communication skills.
- Influencing skills.

Вопрос 153/199

COSM 512: EV (Earned Value) represents:

Выберите один ответ:

- Budgeted cost of work scheduled.
- Budgeted cost of work planned.
- Budgeted cost of work to complete.
- Budgeted cost of work performed.

Вопрос 154/199

SP 232: A new project manager is about to begin creating the project's scope of work. One stakeholder wants to add many items to the scope of work. Another stakeholder only wants to describe the functional requirements. The project is important for the project manager's company but a seller will do the work. Which of the following would you advise the project manager to do?

Выберите один ответ:

- Postpone the project until all parties agree.
- The scope of work should be detailed to allow clarifications later.
- The scope of work should be general to allow the seller to make its own decisions.
- The scope of work should be as detailed as necessary for the type of project.

Вопрос 155/199

RP 867: In risk management one typical display of sensitivity analysis is which of the following?

Выберите один ответ:

- Tornado diagram.
- Experience of the project manager.
- Opinion of the sponsor
- Bias of the stakeholders.

Вопрос 156/199

RM 872: During the course of your project an identified risk materializes. Your project has provisions for contingency and management reserves. How should these be accounted for?

Выберите один ответ:

- Known reserve.
- Safety reserve.
- Management reserves
- Contingency reserves

Вопрос 157/199

COMM 719: During a presentation the project manager would rather do all the following EXCEPT:

Выберите один ответ:

- Use Network diagram instead of Gantt chart to show interdependences between activities.
- Use Gantt chart instead of Network diagram to track progress and to report to the team.
- Use the WBS (Work Breakdown Structure) to show interdependences between activities.
- Use Milestone chart instead of Gantt chart to report to senior management.

Вопрос 158/199

PP 052: Changes to a contract are approved and signed by both the buyer and seller as the desired performance requirements. These changes are .

Выберите один ответ:

- An integral part of the prime contract as an amendment.
- Separate contracts between the customer and the project.
- Stand-alone subcontracts to the prime contract.
- Secondary in legality to the prime.

Вопрос 159/199

TP 356: The Estimate Durations process requires that the _____ required to complete the activity is estimated and the amount of resources to be applied to complete the activity is estimated.

Выберите один ответ:

- Period.
- Duration.
- Amount of work effort.

- Elapse time.

Вопрос 160/199

SP 248: SMART objective stands for which of the following:

Выберите один ответ:

- Specific, measurable, accountable for, realistic, and time based.
- Situational.
- Not complex.
- Specific, measurable, assignable, realistic, and time based.

Вопрос 161/199

SP 255: The project charter and the project statement of work are intended to spell out the content of the project for:

Выберите один ответ:

- Anyone associated with the project.
- Project Manager.
- Customer.
- Team members.

Вопрос 162/199

HP 662: What is the most important skills which you would look for in a project manager?

Выберите один ответ:

- Influencing skills.
- Communication skills.
- Negotiation skills.
- Problem-solving skills.

Вопрос 163/199

COMI 717: Which of the following statements is NOT correct?

Выберите один ответ:

- Stakeholders can have an adverse impact on the project objectives.
- A project can be perceived as having both positive and negative results by the stakeholders.
- The interests of negative stakeholders are served by not impeding the project's success.
- Stakeholders can have a positive impact on the project objectives.

Вопрос 164/199

II 32: With interest rate equals to 10%, the Present Value of €300 000 received 3 years from now is:

Выберите один ответ:

- €330 000
- €225 394
- €215 012
- €300 000

Вопрос 165/199

COSM 525: In Earned Value, the ETC (Estimate to Complete) usually:

Выберите один ответ:

- includes some adjustment to the original cost estimate based on project performance to date.
- stands for "Evaluation of Total Cost".
- stands for "Earned Total Cost".
- stands for "Estimate total cost".

Вопрос 166/199

COSP 588: Which of the following would be an example of parametric estimating?

Выберите один ответ:

- Add bottom up the cost of all the work packages necessary to build the pipeline.
- Finding a company which laid a similar pipeline and ask for a quote.
- Add top down the cost of all the work packages necessary to build the pipeline.
- Estimating the cost of laying a pipeline by multiplying the average cost of one kilometre of pipeline by the total length of the pipeline.

Вопрос 167/199

TM 312: Which statement is correct regarding critical path?

Выберите один ответ:

- Some non critical tasks may become critical once resources are leveled.
- The more you reduce the time of an activity on the initial critical path, the shorter the project.
- A task is either critical or it is not regardless of statistical deviation of its duration.
- Critical path calculation includes all the tasks with the longest duration.

Вопрос 168/199

1M 7: You are a project manager about to start to "carry over the project": Your sponsor is nervous: he should like to know if the project objectives which were initially set can be achieved. You will decide to show him which of the following documents?

Выберите один ответ:

- The project charter.
- The RFP (Request for Proposal).
- The project management plan.
- The SOW (Statement of Work).

Вопрос 169/199

COSP 571: The _____ is usually based upon the corporate chart of accounts of the primary performing organization

Выберите один ответ:

- Cost Budgeting.
- Project chart of accounts
- Code of Accounts.
- Contingency Reserve.

Вопрос 170/199

XX 017: You found a mistake in your report that was already sent out to key stakeholders. Your next step would be:

Выберите один ответ:

- Offer your resignation.
- Do nothing as it is too late and nobody will notice.
- Blame someone else for the mistake, or attempt to cover it up.
- Take ownership and make corrections promptly

Вопрос 171/199

SP 235: All the following factors should be included in the Requirement management plan EXCEPT:

Выберите один ответ:

- What metrics will be used to trace the requirements.
- Which requirements are realistic
- How planning, tracking, and reporting requirements activities will occur.
- How requirements will be prioritized.

Вопрос 172/199

RP 905: To break even, what should a lottery ticket cost if a player has a 50% chance to receive 50 \$ and a 50% chance to have to pay 30\$.

Выберите один ответ:

- 30 \$
- 5\$
- 10\$
- 15\$

Вопрос 173/199

QM 025: Which type of warranty is enacted if a service or product does NOT meet the level of quality specified in the contract?

Выберите один ответ:

- Implied warranty of specified quality
- Express warranty
- Implied warranty of merchantability.
- Billable warranty.

Вопрос 174/199

HE: A project requires long teleconferences. The project team asks the project manager to be provided with headsets. The project manager convinces/agrees with the sponsor to provide headsets. This is a form of:

Выберите один ответ:

- Hygiene factor
- Acceptance.
- Esteem.
- Recognition

Вопрос 175/199

XX 018: You have decided to soon leave the company and work for the competition. Your boss does not yet know. He gives you some very sensitive information which could backfire on the company once you leave. What should you do?

Выберите один ответ:

- Take the information as it can be useful to promote your career in the other company soon.

- Inform your boss that you will shortly be leaving the company and that it would be inappropriate for you to work on these documents.
- Decline to take the documents because of the conflict of interest.
- "Business as usual" since your boss does not know yet.

Вопрос 176/199

HE: A mandatory prerequisite for team building is:

Выберите один ответ:

- Removal of troublesome individuals.
- Commitment from top level management.
- Funding for staff development activities.
- Shared work ethics among team members.

Вопрос 177/199

QP 041: In quality management which of the following represents a cost of conformance?

Выберите один ответ:

- Liability judgments.
- Product design validation.
- Warranty repairs or service
- Complaint handling.

Вопрос 178/199

SP 218 : The scope statement provides all the following EXCEPT:

Выберите один ответ:

- Risk categories.
- Product description.
- Acceptance criteria.
- Project boundaries

Вопрос 179/199

COMP 729: The following are macro barriers to successful communication EXCEPT:

Выберите один ответ:

- Information overload.
- Cultural differences
- Number of links.

- Good subject knowledge.

Вопрос 180/199

XX 020: You would prefer to hire a project manager who:

Выберите один ответ:

- Has strong connections with local business.
- Hardly ever loses in negotiations.
- Knows how to "get the last drop" out of all suppliers.
- Has genuine integrity and expertise.

Вопрос 181/199

IP 22: The project management plan is usually developed by:

Выберите один ответ:

- Project team.
- Quality assurance department.
- Project manager
- Sponsor.

Вопрос 182/199

COMP 728: The five stages of negotiation are:

Выберите один ответ:

- Introduction, probing, scratch bargaining, closure, departure.
- Protocol, probing, scratch bargaining, closure, departure.
- Protocol, probing, scratch bargaining, conclusion, agreement.
- Protocol, probing, scratch bargaining, closure, agreement.

Вопрос 183/199

PE 008: A fixed-price-plus-incentive-fee (FPI) contract has a target cost of \$130,000, a target profit of \$15,000, a target price of \$145,000, a ceiling price of \$160,000, and a share ratio of 80/20. The actual cost of the project was \$150,000. How much profit does the seller make?

Выберите один ответ:

- \$15,000
- \$0
- \$10,000
- \$5,000

Вопрос 184/199

SM: 202 and are outputs to the process "Verify Scope"

Выберите один ответ:

- Performance reports, Accepted deliverables.
- Project management plan, Performance reports.
- Accepted deliverables, Change requests.
- Change control meetings, Accepted deliverables.

Вопрос 185/199

COSP 583: The S-Curve is used to display which of the following?

Выберите один ответ:

- Cost performance baseline.
- Funding requirements.
- Budgeted cost of work performed.
- Actual cost.

Вопрос 186/199

RM 879: A watch list is an output of:

Выберите один ответ:

- Perform Quantitative risk analysis.
- Watch out and monitor risks.
- Perform Qualitative risk analysis.
- Plan risk management.

Вопрос 187/199

XX 019: You heard that your colleague is selling illegal copies of the PMBOK. You would then:

Выберите один ответ:

- Close your eyes otherwise there would be too many reports of violation.
- Do nothing as only substantiated ethics violations should be reported.
- Report that violation.
- Buy a copy as it is cheap

Вопрос 188/199

QM 034: You are checking if the bridge which your team has just built answers all the items of the UAT (User Acceptance Test). You are performing which of the following processes?

Выберите один ответ:

- Quality Control Activity - Inspection.
- Quality Assurance activity - Prevention.
- Risk Identification to prevent issues when the customer will do its own checking.
- Smart anticipation

Вопрос 189/199

HP 647: A tool which links the project roles and responsibilities to the project scope definition is called:

Выберите один ответ:

- Project Scope and Roles Matrix.
- Scope Definition Matrix.
- Roles Assignment Matrix
- Responsibility Assignment Matrix.

Вопрос 190/199

RM 838: It is very likely that the prototype will be rejected, but the impact would be low on the project. The following statement illustrates which of the following:

Выберите один ответ:

- Risk aversion.
- Risk response..
- Risk identification.
- Risk analysis.

Вопрос 191/199

II 71: The following constitutes the "Project management process groups"

Выберите один ответ:

- Initiating, planning, executing, controlling, and closing.
- Initiating, planning, contracting, executing, and administration.
- Starting, planning, executing, controlling, and closing.
- Initiating, designing, planning, executing, controlling, and implementation.

Вопрос 192/199

XX 001: Boris is working in a former Soviet Republic country and knows that bribes are a legitimate custom in doing business locally. Boris is employed by a German company. He well knows that German law does not allow any kinds of bribery. He tries to get some goods delivered at the border through custom. He is requested to pay a \$6,000 "facilitation's fee" to the local custom officer. What would the right attitude be?

Выберите один ответ:

- Pay only if any kind of receipt can be obtained.
- Try to bring the fee down.
- Pay the money to the local official.
- Do not pay, even if it jeopardizes the project.

Вопрос 193/199

QP 032: The process "Plan Quality" belongs to which process group(s):

Выберите один ответ:

- To all groups because you constantly plan and monitor quality.
- Planning.
- Initiation.
- Initiation and Planning.

Вопрос 194/199

TP: The objective of _____ is to redefine the logic in a project to accomplish activities in parallel as start-to-start, rather than finish-to-start, relationships. activity cannot be started because of physical constraints until the predecessor activity has been finished.

Выберите один ответ:

- Crashing.
- Mitigating.
- Rushing.
- Fast tracking.

Вопрос 195/199

RP 822: In risk management the sensitivity analysis does:

Выберите один ответ:

- Help to determine which risks have the most potential impact on the project.
- Categorize the diverging estimates of the stakeholders.
- Take into account the sensitivity of the estimators.
- Take in account why the perception of risk differs from person to person.

Вопрос 196/199

II 70: In the business case the author has considered the following: There is 25% chance to make a 20 million € profit; there is 25% chance to make another 6 million € of profit; and there is 10% chance to make a 10 million € loss. The approval board should reckon with an average financial outcome of:

Выберите один ответ:

- 5, 5 million €.
- 6,5 million €.
- 26 million €.
- 16 million €.

Вопрос 197/199

QP 013: A _____ diagram is a histogram ordered by frequency of occurrence that shows how many results were generated by each identified cause.

Выберите один ответ:

- Pareto.
- Ushi Kawa.
- TQM.
- Gantt.

Вопрос 198/199

QP 037: are unusual, not previously observed, non-quantifiable variation.

Выберите один ответ:

- Traceable-causes.
- Random-causes.
- Unknown-causes.
- Special-causes.

Вопрос 199/199

IE 119: Which of the following is NOT a function of a Configuration Management System?

Выберите один ответ:

- To identify and document the functional and physical characteristics of an item or system and control any changes to those characteristics.
- To determine if a requested change is to be applied to management or project reserves.

- Auditing the items and system to verify conformance to requirements.
- Recording and reporting the change and its implementation status